

LH₂

Cryogenic Components

for future energy carriers

LNG



WEKA



Certified according
ISO 9001:2000



Certified according
PED 97/23/EC



Certified according
ATEX 94/9/EC

Member of the  Group

Cryogenic Components for future energy carriers (LNG, LH₂):

PURIFICATION

LIQUEFACTION

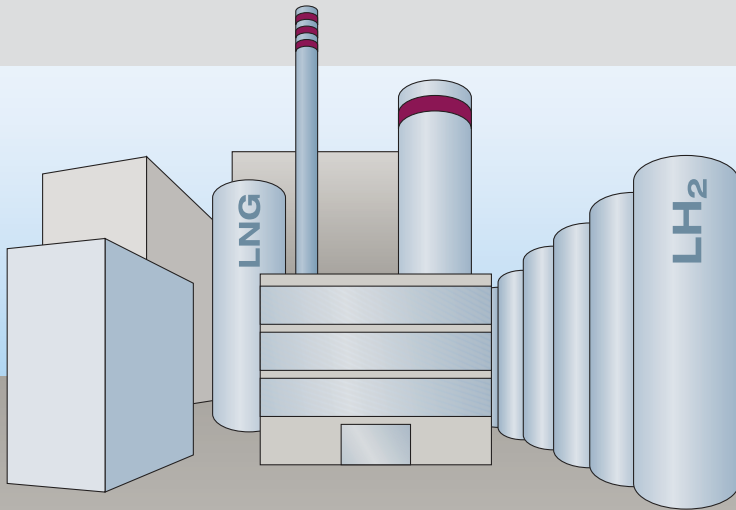

WEKA Cryogenic Components provide optimal solutions for handling of low-temperature liquefied gases under extreme operating conditions. WEKA Cryogenic Components are generally used in applications involving liquid and gaseous media below 120 K (-153 °C). Liquid hydrogen (LH₂) has been used as fuel in space vehicles, and is now drawing attention as an alternative energy carrier. By liquefying natural gas (LNG) the storage capacity and the driving distance of vehicles could be enlarged.

WEKA has more than 30 years of experience in designing and manufacturing valves for hydrogen and natural gas. In the world-wide hydrogen production, more than 250 WEKA valves are daily in use. Our valves could be used in different production steps: purification, liquefaction, distribution and on board (= mobile systems).



**GH₂ valve,
PM-WEV
DN125/PN25**

The highlights of our valves are:

- Nominal pressure up to 700 bar (resp. 1000 bar)
- Complete welded body in 316L (certificates of pressure retaining parts on request)
- Sealing with bellows, Quad-ring or spring-loaded v-ring
- Easy update from on/off-valve to control valve
- Separated tightness and flow control function
- Vacuum weld'in flange in different diameters
- For control valves: digital positionner with different interfaces



**LNG valve,
HI-TEV
DN15/PN25**

DISTRIBUTION

ON BOARD

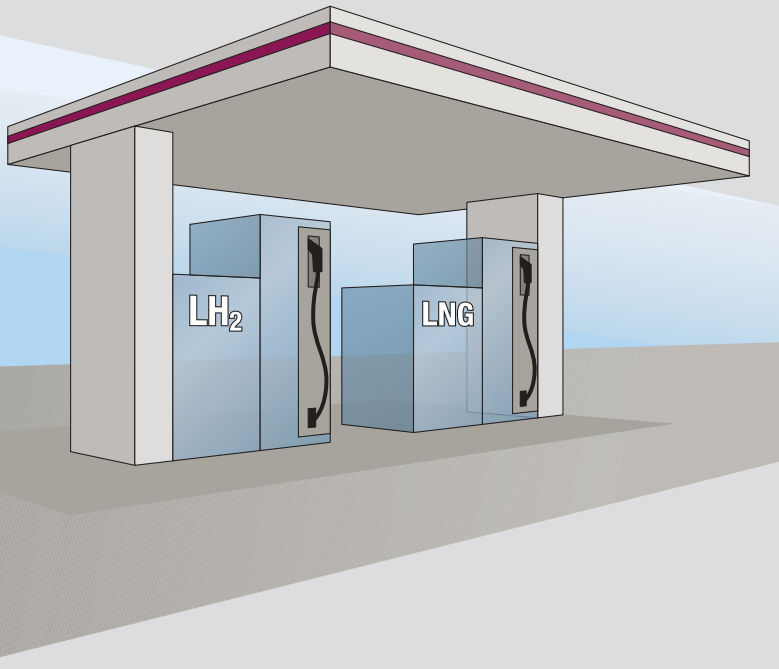

LH₂ valve, PM-TDV DN15/PN40

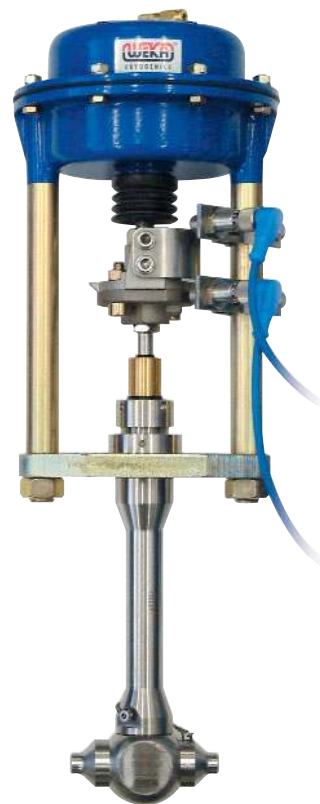

High pressure valve,
PM-KDFV DN6/PN420

WEKA Cryogenic Components are also used for low-temperature liquid and cryogenic gases, such as oxygen (O₂, normal boiling point 90 K), argon (Ar, normal boiling point 87 K), nitrogen (N₂, normal boiling point 77 K), and hydrogen (H₂, normal boiling point 20 K), besides rare gases such as xenon (Xe) and neon (Ne).

The current manufacturing program for WEKA Cryogenic Components includes the following products:

- Cryogenic shut-off and control valves for installation in valve boxes or fitted in vacuum jackets
- Special types of cryogenic valves: check valves, pilot valves, overflow valves, etc.
- Coupling systems for cryogenic transfer lines (Johnston and multi-coaxial couplings)
- Compact valves for space cryogenic systems
- Custom designed and manufactured cryogenic components: e.g., cryostats, cold ejectors, prototypes etc.

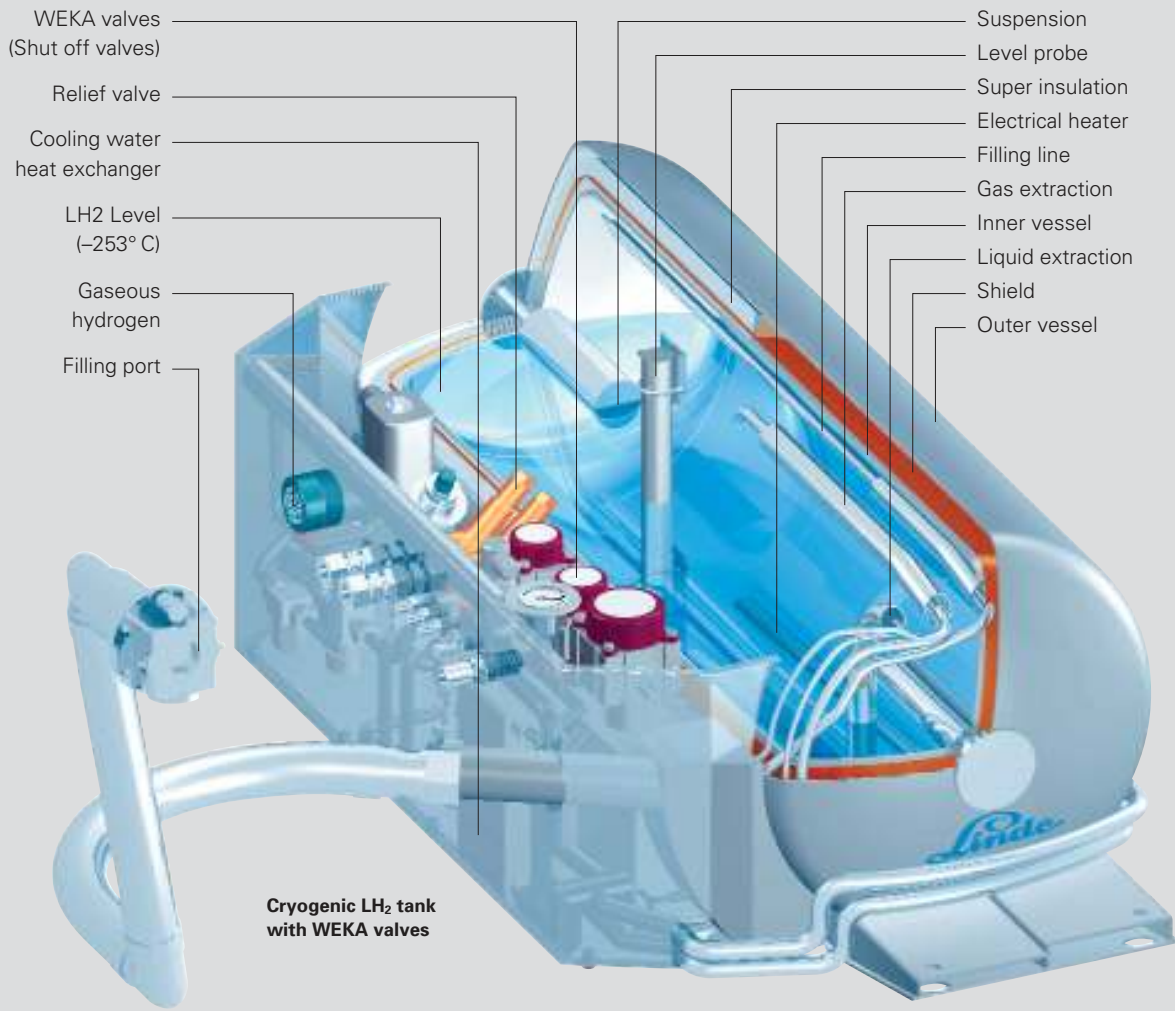

Cryogenic LH₂ tank with WEKA valves

Based on the long-term experience WEKA has developed a special valve with integrated pneumatic actuator for liquid hydrogen (LH₂) application.

Due to limited space the valves had to be very short. The actual valve design has an overall length of 300 mm. Resulting fact is, that the valve has to handle a temperature gradient of over 200 degrees over a cryogenic length of 130 mm. To prevent freezing at the warm end of the valve, WEKA designed a compound spindle of extremely low heat load, made in composite material.

The valves are built in a LH₂ tank, where every tank needs two or three valves. The figure above shows the basic elements of such a tank.

Spring loaded cap (safety position)

Pneumatic piston actuator

Weld-in flange for vacuum insulation

Minimized cryogenic length (h = 130 mm)

Housing with Z-pattern inlet and outlet 90° rotated

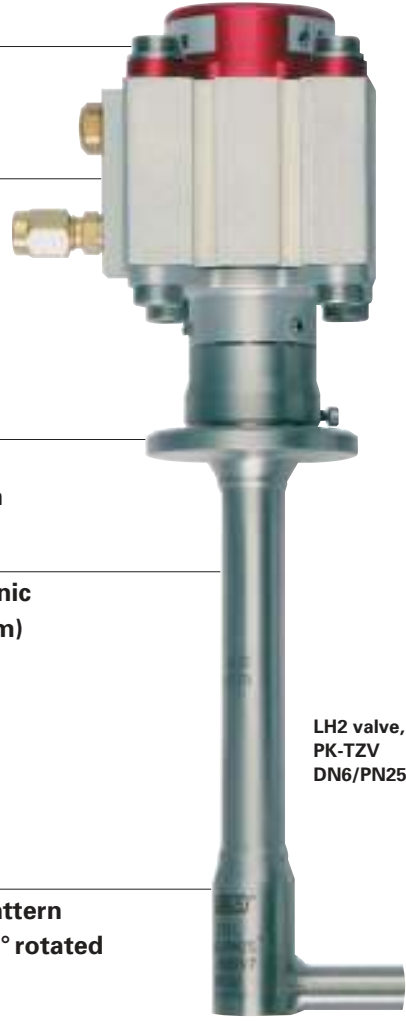

LH₂ valve, PK-TZV DN6/PN25



Germanischer Lloyd



TUV



Competence
Quality
Flexibility



- 1940** Arthur **Welter** and August **Karrer** create **WEKA** GmbH.
- 1949** Company reorganized as WEKA AG.
- 1950** WEKA Stainless Steel Valves introduced.
- 1962** First patent for WEKA Visual Level Indicators.
- 1978** First Cryogenic Valves and Components manufactured.
- 1979** Licensing agreement with GEMS Sensors, USA, for WEKA Visual Level Indicators.
- 1981** WEKA becomes a member of the IMO Group, USA.
- 1982** Certified for manufacturing pressure vessels per AD-HP 0 and SVDB501.
Audit completed of the first WEKA QS System.
- 1991** Establishment of new building in Baeretswil, 25 km southeast of Zurich.
- 1995** European manufacturing of GEMS Tank Level Indicators started.
- 1997** WEKA, as part of the GEMS Group, acquired by Danaher Corp., USA.
- 2001** WEKA becomes a member of the ARCA Group. ARCA Regler GmbH is a reputed German mid-sized company, renowned for its regulating valves.
- 2002** WEKA Total Quality Management System audited and certified by Germanischen Lloyd per ISO 9001:200 and 97/23/EG (PED).
- 2003** Certified by ZELM Ex per 94/9/EG (ATEX 95).



A member of the ARCA Flow Group:



Visual Level Indicators



Stainless Steel Valves



Tank Level Indicators



Visual Level Indicators
Tank Level Indicators
Cryogenic Components
Stainless Steel Valves



WEKA AG, Schürlistrasse 8
CH-8344 Bäretswil, Switzerland
Phone +41 (0)43 833 43 43
Fax +41 (0)43 833 43 29
info@weka-ag.ch · www.weka-ag.ch