

**Bi-directional deflagration flame arrester**  
**KITO EFA-Def0-IIA-.../...-X16**  
**KITO EFA-Def0-IIA-.../...-X16-T (-TT)**

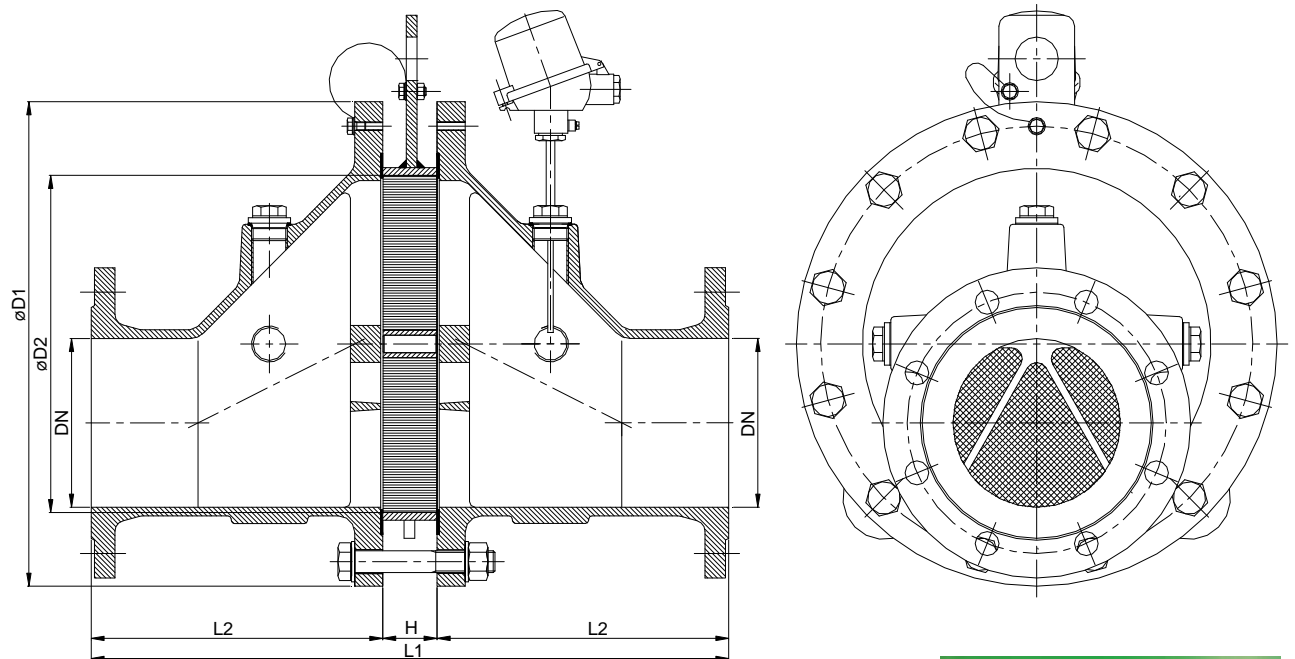

Größe	DN	ANSI	D1	D2	L1	H	L2	kg*
65	25	1"	155	70	290	50	120	11
	32	1 1/4"						12
100	40	1 1/2"	220	106	340	50	145	24
	50	2"						26,5
150	50	2"	285	159	400	50	175	26
	65	2 1/2"						42
200	80	3"	340	206	450	50	200	44
	100	4"						
300	100	4"	445	308	590	50	270	
	125	5"						
	150	6"						110

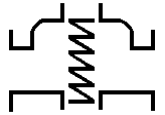

Type examination certificate to ISO 16852 and EN 12874

CE -designation in accordance to ATEX-Guideline 94/9/EG

Dimensions in mm

\* weights refer to the standard design

Design subject to change

For performance curves see diagram: H 0.37 N

Standard design

housing : cast steel 1.0619,  
 stainless cast steel 1.4408  
 gasket : HD 3822, PTFE  
 casing for grid : 1.0305, stainless steel mat. no.  
 1.4571, 1.4581  
 grid : stainless steel mat. no. 1.4310, 1.4571,  
 strip thickness 0.15 mm  
 bolts/nuts : galvanized steel, SS  
 temperature sensor : PT 100 (option); connection 3/8"  
 flange connection : DIN 1092-1 PN 10/16 Form B1,  
 ANSI 150 lbs. RF

Application

For installation into pipelines to the protection of containers and components against deflagration of flammable liquids and gases. Approved for all substances of explosion groups IIA1 to IIA with a maximum experimental safe gap (MESG) > 0.9 mm. Bi-directionally working in pipelines, whereby an operating pressure of 1.1 bar abs. and an operating temperature of 160°C must not be exceeded. The distance between a potential ignition source and the flame arrester must not exceed 50 times the inner pipe diameter. The installation of the deflagration flame arrester into horizontal and vertical pipelines is permissible. Provided with one or two temperature sensors (PT 100) the armature is certified against short time burning from one or both sides. If only one thermal sensor is attached, it must be installed into that part of the body from which a fire is expected.

Example for orders :

**KITO EFA-Def0-IIA-100/40-X16-T**  
 (design with thermo couple element)

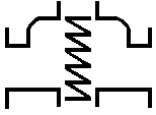

**Bi-directional deflagration flame arrester**  
**KITO EFA-Def0-IIA-.../...-X16**  
**KITO EFA-Def0-IIA-.../...-X16-T (-TT)**

The flow capacity  $V$  refers to a density of air with  $\rho = 1.29 \text{ kg/m}^3$  at  $T = 273 \text{ K}$  and a pressure of  $p = 1.013 \text{ mbar}$

The flow capacity for gases with different densities can be calculated sufficiently accurate by the following approximation equation:

$$\dot{V} = \dot{V}_b \cdot \sqrt{\frac{\rho_b}{1.29}} \quad \text{or} \quad \dot{V}_b = \dot{V} \cdot \sqrt{\frac{1.29}{\rho_b}}$$

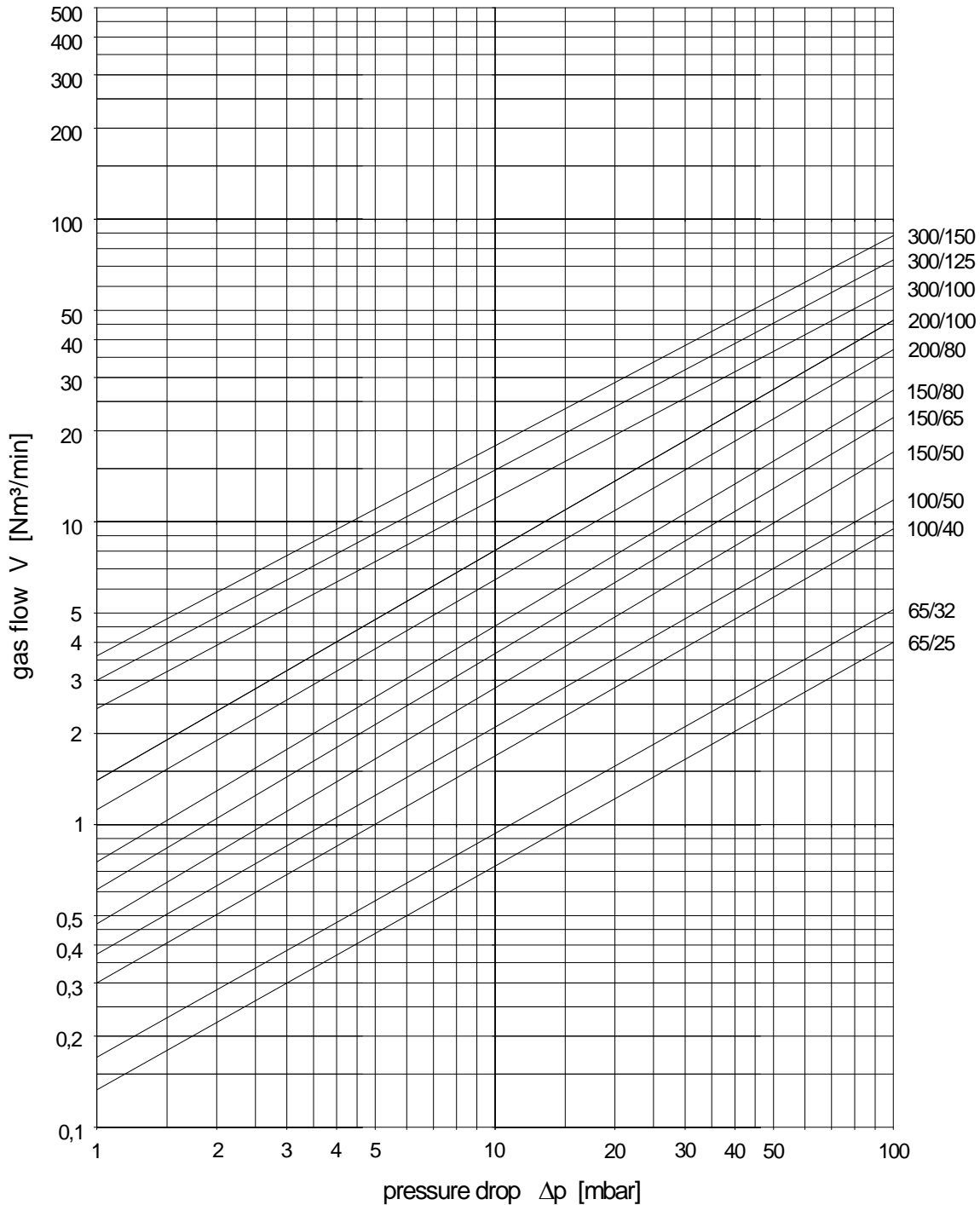

Design subject to change