

Bi-directional deflagration flame arrester

KITO EFA-Def0-I-.../...-1.2

KITO EFA-Def0-I-.../...-1.2-T (-TT)

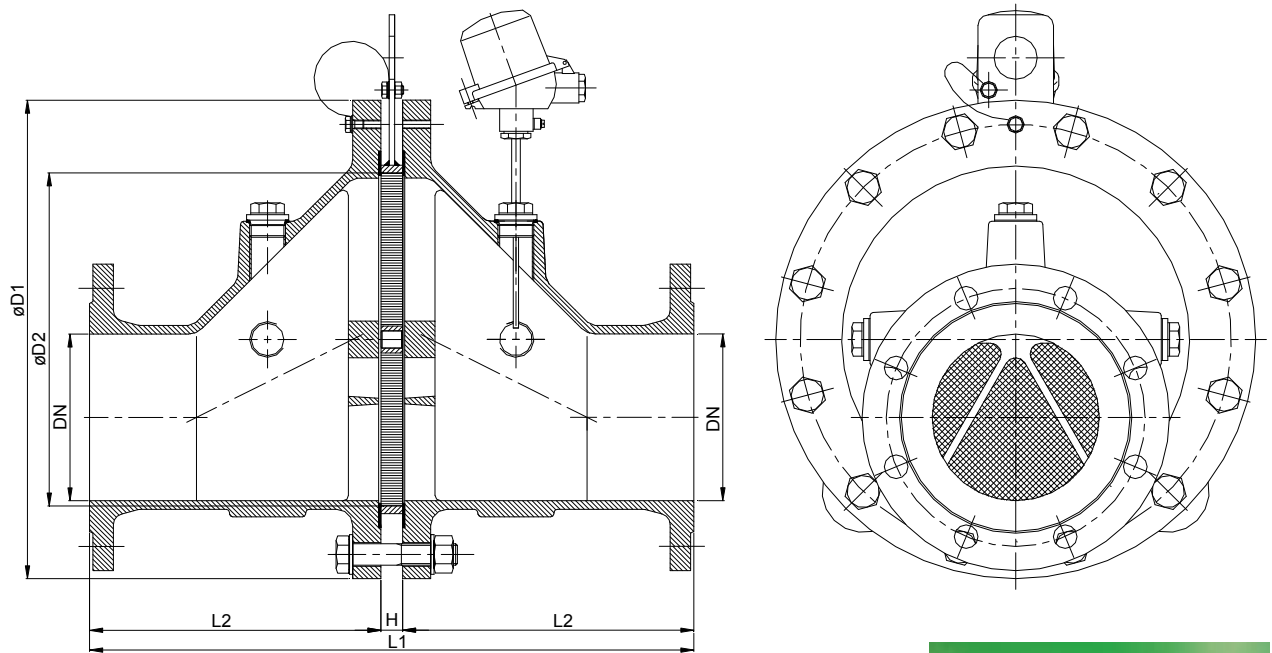
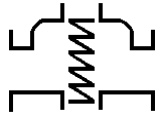

Größe	DN	ANSI	D1	D2	L1	H	L2	kg*
65	25	1"	155	70	260	20	120	10
	32	1 1/4"						12
100	40	1 1/2"	220	106	310	20	145	22
	50	2"						24
150	50	2"	285	159	370	20	175	34
	65	2 1/2"						38
	80	3"						40
200	80	3"	340	206	420	20	200	52
	100	4"						54
300	100	4"	445	308	560	20	270	93
	125	5"						95
	150	6"						100
400	150	6"	565	388	650	20	315	161
	200	8"						231
500	200	8"	670	485	780	20	380	238
	250	10"						309
600	250	10"	780	584	920	20	450	362
	300	12"						
800	350	14"	1015	810	1287	47	620	
	400	16"						



Type examination certificate to ISO 16852 and EN 12874

CE -designation in accordance to ATEX-Guideline 94/9/EG

Dimensions in mm

* weights refer to the standard design

Design subject to change

For performance curves see diagram: H 0.33 N

Standard design

housing : cast steel 1.0619, stainless cast steel 1.4408
 gasket : HD 3822, PTFE
 casing for grid : 1.0305, stainless steel mat. no. 1.4571, 1.4581
 grid : stainless steel mat. no. 1.4310, 1.4571, strip thickness 0.15 mm
 bolts/nuts : galvanized steel, SS
 temperature sensor : PT 100 (option); connection 3/8"
 flange connection : DIN 1092-1 PN 10/16 Form B1, ANSI 150 lbs. RF

Example for orders :

KITO EFA-Def0-I-100/40-1.2-T
 (design with thermo couple element)

Application

For installation into pipelines to the protection of containers and components against deflagration of flammable liquids and gases. Approved for all substances of explosion group IIA1 (old : I) with a maximum experimental safe gap (MESG) ≥ 1.14 mm.

Bi-directionally working in pipelines, whereby an operating pressure of 1.2 bar abs. and an operating temperature of 60°C must not be exceeded. The distance between a potential ignition source and the flame arrester must not exceed 50 times the inner pipe diameter. The installation of the deflagration flame arrester into horizontal and vertical pipelines is permissible. If only one thermal sensor is attached, it must be installed into that part of the body from which a fire is expected.

The sizes 65 to 300 are flame proof against stabilized burning if they are installed into horizontal pipelines. In case of a vertical installation and all other sizes, the flame arrester is only certified against short time burning from one or both sides, if one respectively two thermocouples are implemented into the body.

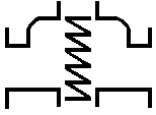

Performance Curves

KITO EFA-Def0-I-.../...-1.2

KITO EFA-Def0-I-.../...-1.2-T (-TT)

The flow capacity V refers to a density of air with $\rho = 1.29 \text{ kg/m}^3$ at $T = 273 \text{ K}$ and a pressure of $p = 1.013 \text{ mbar}$. The flow capacity for gases with different densities can be calculated sufficiently accurate by the following approximation equation:

$$\dot{V} = \dot{V}_b \cdot \sqrt{\frac{\rho_b}{1.29}} \quad \text{or} \quad \dot{V}_b = \dot{V} \cdot \sqrt{\frac{1.29}{\rho_b}}$$

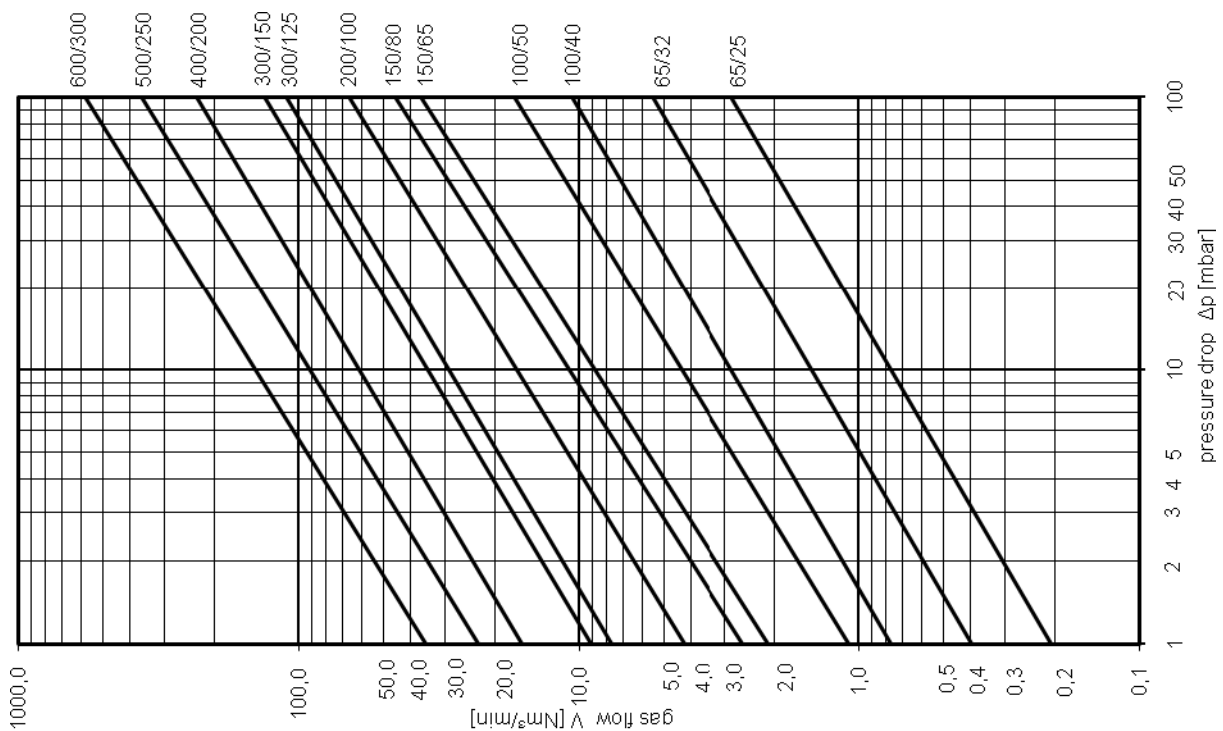
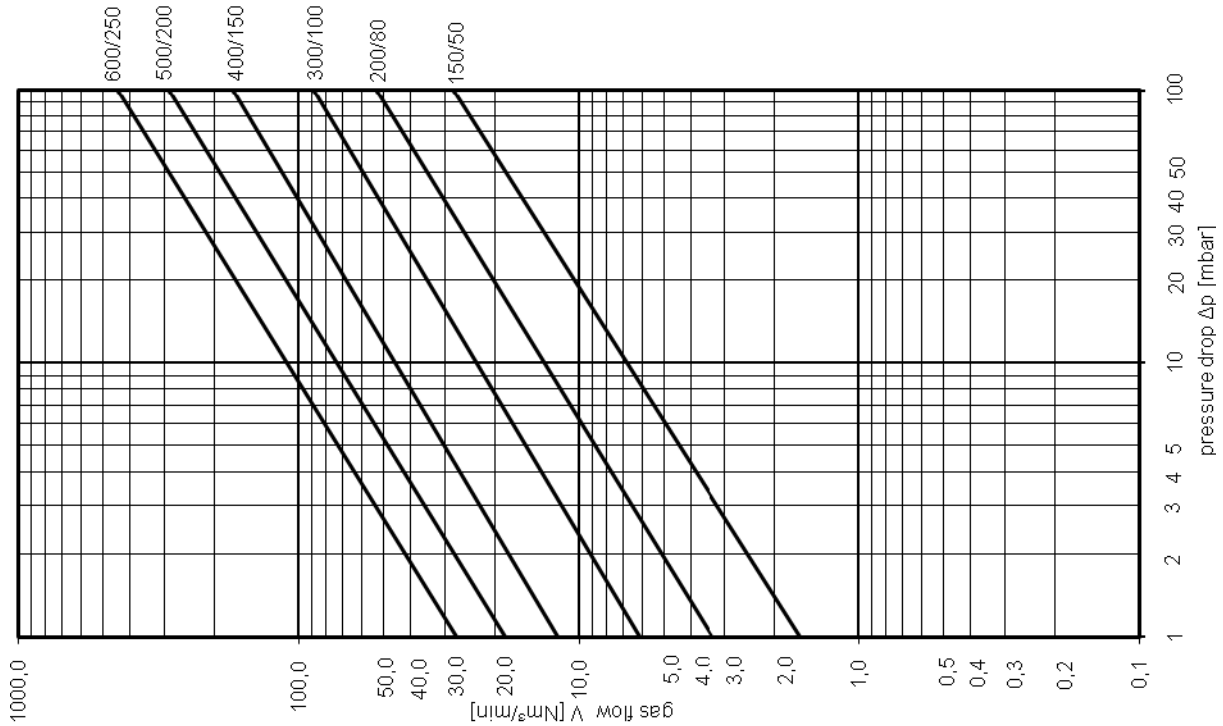

Design subject to change