



# Trimod<sup>o</sup> Besta



## Contents

<b>The perfect combination</b>	Trimod Besta level switches in Besta float chambers	4
<b>Standard chambers for low cost applications</b>	Standard chambers PN 25 with process connections acc. to DIN with process connections acc. to ANSI cl. 150 with process connections acc. to ANSI cl. 300	5 6 7 8
<b>Industrial chambers for high pressure applications</b>	Industrial chambers acc. to DIN and ANSI Industrial chambers DIN PN 40 Industrial chambers DIN PN 63 Industrial chambers ANSI cl. 150 Industrial chambers ANSI cl. 300 Industrial chambers ANSI cl. 400/600	9 10 11 12 13 14
<b>Options</b>	Taylor made float chambers	15
<b>Operating pressure</b>	Pressure-temperature-diagram	16
<b>Quality</b>	Tests and reports	17
<b>Experts rely on Besta</b>	Approvals	18
<b>Specification sheet</b>	Float chamber specification sheet	19

## The perfect combination: Trimod Besta level switches in Besta float chambers

Wherever it is not possible or desirable to install level switches directly onto a vessel, horizontal Trimod Besta level switches can be mounted externally in a float chamber. This type of installation allows functional checks and servicing to be carried out without interrupting operation, provided that isolation and drain valves are included in the process connections.

Please find the Trimod Besta level switches fully described in the Trimod Besta level switch catalogue. If you need a copy please call us.



**Table 1**  
**The 2 Groups of float chambers**

<p><b>Standard chambers PN 25</b></p> <p>In various steel qualities and configurations with process connection acc. to DIN or ANSI.</p> <p>For use with the Trimod Besta level switches from the standard range with:</p> <p>Square flange    type: 01 or Round flange    type: 011</p> <p>See pages 5 to 8</p>	
<p><b>Industrial chambers up to PN 315 acc. to DIN or cl. 2500 acc. to ANSI</b></p> <p>In various steel qualities and configurations with switch- and process connections acc. to DIN or ANSI.</p> <p>For use with the Trimod Besta level switches from the industrial range with DIN-flanges DN 65 or ANSI-flanges DN 3".</p> <p>See pages 9 to 14</p>	

## Low cost standard chambers

Besta standard chambers are designed for applications up to PN 25 acc. to DIN. The wide choice of materials permits operation with corrosive liquids at process temperatures of -200°C up to +400°C. The use of Besta standard chambers provides the most economical chamber option.

**Table 2**  
Suitable Trimod Besta level switches

For correct clearance, only the standard range float modules listed in the table opposite can be used with standard chambers.  Description of the float modules: see Trimod Besta level switch catalogue.	Type of float modules				
	01	07	013	053	072
	04	011	051	054	073
	041	012	052	071	074

**Trimod Besta level switches**  
Standard range



**Besta standard chamber**

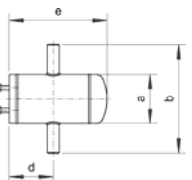
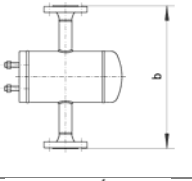
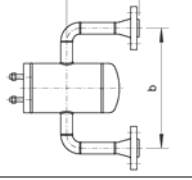
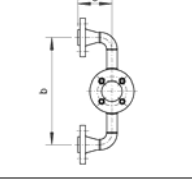
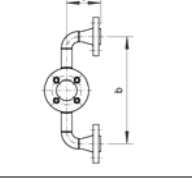
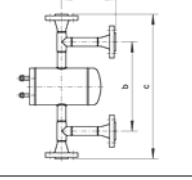
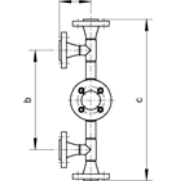
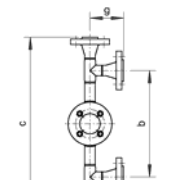

**Table 3**  
Standard chambers PN 25

A	B	C	D	Configurations Process connection  Materials  Flange facing - of process connection  - of switch connection  Level switch gaskets - standard - Hi/Low temp.  Options	acc. to figure A to H DN 25, 50 acc. to DIN DN 1", 2" acc. to ANSI  Carbon steel Creep resistant steel CrNi steel (304 equiv.) CrNiMo steel (316 equiv.)  fig. A: butt welding fig. B to H: DIN or ANSI  flat seal face  Garlock Blue Gard 3000 Graphite gaskets  see page 15
E	F	G	H		

## STANDARD CHAMBERS

**Table 4**  
**Standard chambers PN 25, process connections DN acc. to DIN**

Figure	Type	Material	DN	Dimensions						
				a	b	c	d	e	f	g
	S020-1XA S021-1XA S024-1XA S025-1XA	Carbon steel 15 Mo 3 CrNi CrNiMo	25	139.7	290		124	274		
	S020-4XA S021-4XA S024-4XA S025-4XA	Carbon steel 15 Mo 3 CrNi CrNiMo	50	139.7	290		124	274		
	S020-1CB S021-1CB S024-1CB S025-1CB	Carbon steel 15 Mo 3 CrNi CrNiMo	25	139.7	290		124	274		
	S020-4CB S021-4CB S024-4CB S025-4CB	Carbon steel 15 Mo 3 CrNi CrNiMo	50	139.7	290		124	274		
	S020-1CC S021-1CC S024-1CC S025-1CC	Carbon steel 15 Mo 3 CrNi CrNiMo	25	139.7	286		124	274	168	
	S020-4CC S021-4CC S024-4CC S025-4CC	Carbon steel 15 Mo 3 CrNi CrNiMo	50	139.7	346		124	274	168	
	S020-1CD S021-1CD S024-1CD S025-1CD	Carbon steel 15 Mo 3 CrNi CrNiMo	25	139.7	286		124	274		79
	S020-4CD S021-4CD S024-4CD S025-4CD	Carbon steel 15 Mo 3 CrNi CrNiMo	50	139.7	346		124	274		125
	S020-1CE S021-1CE S024-1CE S025-1CE	Carbon steel 15 Mo 3 CrNi CrNiMo	25	139.7	286		124	274		79
	S020-4CE S021-4CE S024-4CE S025-4CE	Carbon steel 15 Mo 3 CrNi CrNiMo	50	139.7	346		124	274		125
	S020-1CF S021-1CF S024-1CF S025-1CF	Carbon steel 15 Mo 3 CrNi CrNiMo	25	139.7	286	444	124	274	168	
	S020-4CF S021-4CF S024-4CF S025-4CF	Carbon steel 15 Mo 3 CrNi CrNiMo	50	139.7	322	548	124	274	168	
	S020-1CG S021-1CG S024-1CG S025-1CG	Carbon steel 15 Mo 3 CrNi CrNiMo	25	139.7	286	444	124	274		79
	S020-4CG S021-4CG S024-4CG S025-4CG	Carbon steel 15 Mo 3 CrNi CrNiMo	50	139.7	322	548	124	274		113
	S020-1CH S021-1CH S024-1CH S025-1CH	Carbon steel 15 Mo 3 CrNi CrNiMo	25	139.7	286	444	124	274		79
	S020-4CH S021-4CH S024-4CH S025-4CH	Carbon steel 15 Mo 3 CrNi CrNiMo	50	139.7	322	548	124	274		113

**Table 5**  
**Standard chambers PN 25, process connections DN acc. to ANSI cl. 150**

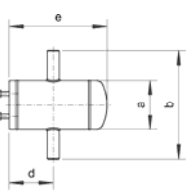
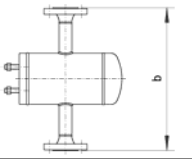
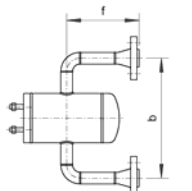
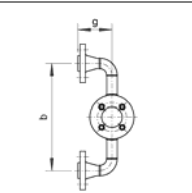
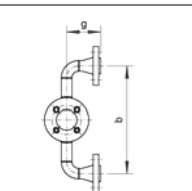
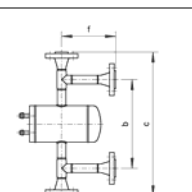
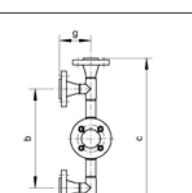
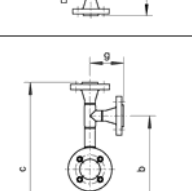
Figure	Type	Material	DN	Dimensions						
				a	b	c	d	e	f	g
	A S110-1XA S114-1XA S115-1XA	Carbon steel CrNi CrNiMo	1"	139.7	320		124	274		
	S110-4XA S114-4XA S115-4XA	Carbon steel CrNi CrNiMo	2"	139.7	320		124	274		
	B S110-1RB S114-1RB S115-1RB	Carbon steel CrNi CrNiMo	1"	139.7	307		124	274		
	S110-4RB S114-4RB S115-4RB	Carbon steel CrNi CrNiMo	2"	139.7	307		124	274		
	C S110-1RC S114-1RC S115-1RC	Carbon steel CrNi CrNiMo	1"	139.7	272		124	274	194	
	S110-4RC S114-4RC S115-4RC	Carbon steel CrNi CrNiMo	2"	139.7	332		124	274	194	
	D S110-1RD S114-1RD S115-1RD	Carbon steel CrNi CrNiMo	1"	139.7	272		124	274		95
	S110-4RD S114-4RD S115-4RD	Carbon steel CrNi CrNiMo	2"	139.7	332		124	274		141
	E S110-1RE S114-1RE S115-1RE	Carbon steel CrNi CrNiMo	1"	139.7	272		124	274		95
	S110-4RE S114-4RE S115-4RE	Carbon steel CrNi CrNiMo	2"	139.7	332		124	274		141
	F S110-1RF S114-1RF S115-1RF	Carbon steel CrNi CrNiMo	1"	139.7	272	462	124	274	194	
	S110-4RF S114-4RF S115-4RF	Carbon steel CrNi CrNiMo	2"	139.7	308	565	124	274	194	
	G S110-1RG S114-1RG S115-1RG	Carbon steel CrNi CrNiMo	1"	139.7	272	462	124	274		95
	S110-4RG S114-4RG S115-4RG	Carbon steel CrNi CrNiMo	2"	139.7	308	565	124	274		129
	H S110-1RH S114-1RH S115-1RH	Carbon steel CrNi CrNiMo	1"	139.7	272	462	124	274		95
	S110-4RH S114-4RH S115-4RH	Carbon steel CrNi CrNiMo	2"	139.7	308	565	124	274		129

## STANDARD CHAMBERS

**Table 6**  
**Standard chambers PN 25, process connections DN acc. to ANSI cl. 300**

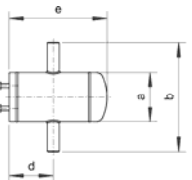
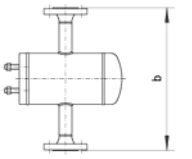
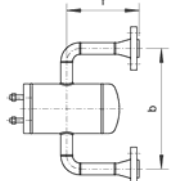
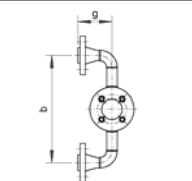
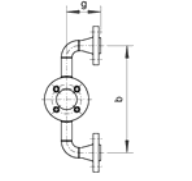
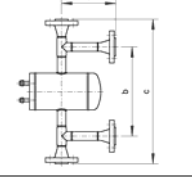
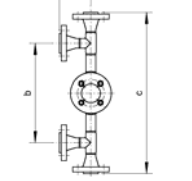
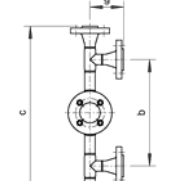
Figure	Type	Material	DN	Dimensions						
				a	b	c	d	e	f	g
	S120-1XA S124-1XA S125-1XA	Carbon steel CrNi CrNiMo	1"	139.7	320		124	274		
	S120-4XA S124-4XA S125-4XA	Carbon steel CrNi CrNiMo	2"	139.7	320		124	274		
	S120-1RB S124-1RB S125-1RB	Carbon steel CrNi CrNiMo	1"	139.7	307		124	274		
	S120-4RB S124-4RB S125-4RB	Carbon steel CrNi CrNiMo	2"	139.7	307		124	274		
	S120-1RC S124-1RC S125-1RC	Carbon steel CrNi CrNiMo	1"	139.7	272		124	274	200	
	S120-4RC S124-4RC S125-4RC	Carbon steel CrNi CrNiMo	2"	139.7	332		124	274	200	
	S120-1RD S124-1RD S125-1RD	Carbon steel CrNi CrNiMo	1"	139.7	272		124	274		101
	S120-4RD S124-4RD S125-4RD	Carbon steel CrNi CrNiMo	2"	139.7	332		124	274		141
	S120-1RE S124-1RE S125-1RE	Carbon steel CrNi CrNiMo	1"	139.7	272		124	274		101
	S120-4RE S124-4RE S125-4RE	Carbon steel CrNi CrNiMo	2"	139.7	332		124	274		147
	S120-1RF S124-1RF S125-1RF	Carbon steel CrNi CrNiMo	1"	139.7	272	474	124	274	200	
	S120-4RF S124-4RF S125-4RF	Carbon steel CrNi CrNiMo	2"	139.7	308	578	124	274	200	
	S120-1RG S124-1RG S125-1RG	Carbon steel CrNi CrNiMo	1"	139.7	272	474	124	274		101
	S120-4RG S124-4RG S125-4RG	Carbon steel CrNi CrNiMo	2"	139.7	308	578	124	274		135
	S120-1RH S124-1RH S125-1RH	Carbon steel CrNi CrNiMo	1"	139.7	272	474	124	274		101
	S120-4RH S124-4RH S125-4RH	Carbon steel CrNi CrNiMo	2"	139.7	308	578	124	274		135

## Industrial chambers for high pressure applications

Besta industrial chambers with switch- and process connections acc. to DIN or ANSI are designed for medium to high pressure applications. Pressure range: up to PN 315 acc. to DIN and up to cl. 2500 acc. to ANSI. Temperature range: -200°C to +400°C. On pages 10 to 14 you will find the industrial chambers up to PN 63 and cl. 600. For applications with higher nominal pressures please ask for specific documentations. Typical applications for industrial chambers are: power stations, chemical and petrochemical plants as well as plant construction.

**Table 7**  
Suitable Trimod Besta level switches

For correct clearance, only the industrial range float modules listed in the table opposite can be used with industrial chambers.  Description of the float modules: see Trimod Besta level switch catalogue.  * Not suitable for chambers PN 40	Type of float modules				
	01	76*	03	051	071
04	02	011	052	072	
041	26*	012	053	073	
07	27*	013	054	074	

**Trimod Besta level switches**  
Industrial range



**Besta industrial chamber**



**Table 8**  
Industrial chambers DIN PN 40, 63 and ANSI cl. 150 to 600

A	B	C	D	Configurations Process connection	acc. to figure A to H DN 25, 50 acc. to DIN DN 1", 2" acc. to ANSI
				Flange facing - of process connection  - of switch connection	fig. A: butt welding fig. B to H: flange face acc. to DIN or ANSI flange face acc. to DIN or ANSI
				Level switch gaskets - Standard - Special applications - Ring joint gasket	AFM 34 ME REINZ Chemotherm SPE Carbon or stainless steel
				Options	see page 15

## INDUSTRIAL CHAMBERS

Table 9

Industrial chambers PN 40, process connection DN acc. to DIN / switch connection flange: DN 65

Figure	Type	Material	DN	Dimensions						
				a	b	c	d	e	f	g
	I020-1C1XA I021-1C1XA I024-1C1XA I025-1C1XA	Carbon steel 15 Mo 3 CrNi CrNiMo	25	139.7	290		205	356		
	I020-1C4XA I021-1C4XA I024-1C4XA I025-1C4XA	Carbon steel 15 Mo 3 CrNi CrNiMo	50	139.7	290		205	356		
	I020-1C1CB I021-1C1CB I024-1C1CB I025-1C1CB	Carbon steel 15 Mo 3 CrNi CrNiMo	25	139.7	290		205	356		
	I020-1C4CB I021-1C4CB I024-1C4CB I025-1C4CB	Carbon steel 15 Mo 3 CrNi CrNiMo	50	139.7	290		205	356		
	I020-1C1CC I021-1C1CC I024-1C1CC I025-1C1CC	Carbon steel 15 Mo 3 CrNi CrNiMo	25	139.7	286		205	356	168	
	I020-1C4CC I021-1C4CC I024-1C4CC I025-1C4CC	Carbon steel 15 Mo 3 CrNi CrNiMo	50	139.7	346		205	356	168	
	I020-1C1CD I021-1C1CD I024-1C1CD I025-1C1CD	Carbon steel 15 Mo 3 CrNi CrNiMo	25	139.7	286		205	356		79
	I020-1C4CD I021-1C4CD I024-1C4CD I025-1C4CD	Carbon steel 15 Mo 3 CrNi CrNiMo	50	139.7	346		205	356		125
	I020-1C1CE I021-1C1CE I024-1C1CE I025-1C1CE	Carbon steel 15 Mo 3 CrNi CrNiMo	25	139.7	286		205	356		79
	I020-1C4CE I021-1C4CE I024-1C4CE I025-1C4CE	Carbon steel 15 Mo 3 CrNi CrNiMo	50	139.7	346		205	356		125
	I020-1C1CF I021-1C1CF I024-1C1CF I025-1C1CF	Carbon steel 15 Mo 3 CrNi CrNiMo	25	139.7	286	444	205	356	168	
	I020-1C4CF I021-1C4CF I024-1C4CF I025-1C4CF	Carbon steel 15 Mo 3 CrNi CrNiMo	50	139.7	322	548	205	356	168	
	I020-1C1CG I021-1C1CG I024-1C1CG I025-1C1CG	Carbon steel 15 Mo 3 CrNi CrNiMo	25	139.7	286	444	205	356		79
	I020-1C4CG I021-1C4CG I024-1C4CG I025-1C4CG	Carbon steel 15 Mo 3 CrNi CrNiMo	50	139.7	322	548	205	356		113
	I020-1C1CH I021-1C1CH I024-1C1CH I025-1C1CH	Carbon steel 15 Mo 3 CrNi CrNiMo	25	139.7	286	444	205	356		79
	I020-1C4CH I021-1C4CH I024-1C4CH I025-1C4CH	Carbon steel 15 Mo 3 CrNi CrNiMo	50	139.7	322	548	205	356		113

Table 10

Industrial chambers PN 63, process connection DN acc. to DIN / switch connection flange: DN 65

Figure	Type	Material	DN	Dimensions						
				a	b	c	d	e	f	g
	I030-1E1XA I031-1E1XA I034-1E1XA I035-1E1XA	Carbon steel 15 Mo 3 CrNi CrNiMo	25	168.3	290		237	406		
	I030-1E4XA I031-1E4XA I034-1E4XA I035-1E4XA	Carbon steel 15 Mo 3 CrNi CrNiMo	50	168.3	290		237	406		
	I030-1E1EB I031-1E1EB I034-1E1EB I035-1E1EB	Carbon steel 15 Mo 3 CrNi CrNiMo	25	168.3	350		237	406		
	I030-1E4EB I031-1E4EB I034-1E4EB I035-1E4EB	Carbon steel 15 Mo 3 CrNi CrNiMo	50	168.3	350		237	406		
	I030-1E1EC I031-1E1EC I034-1E1EC I035-1E1EC	Carbon steel 15 Mo 3 CrNi CrNiMo	25	168.3	310		237	406	181	
	I030-1E4EC I031-1E4EC I034-1E4EC I035-1E4EC	Carbon steel 15 Mo 3 CrNi CrNiMo	50	168.3	378		237	406	181	
	I030-1E1ED I031-1E1ED I034-1E1ED I035-1E1ED	Carbon steel 15 Mo 3 CrNi CrNiMo	25	168.3	310		237	406		97
	I030-1E4ED I031-1E4ED I034-1E4ED I035-1E4ED	Carbon steel 15 Mo 3 CrNi CrNiMo	50	168.3	378		237	406		139
	I030-1E1EE I031-1E1EE I034-1E1EE I035-1E1EE	Carbon steel 15 Mo 3 CrNi CrNiMo	25	168.3	310		237	406		97
	I030-1E4EE I031-1E4EE I034-1E4EE I035-1E4EE	Carbon steel 15 Mo 3 CrNi CrNiMo	50	168.3	378		237	406		139
	I030-1E1EF I031-1E1EF I034-1E1EF I035-1E1EF	Carbon steel 15 Mo 3 CrNi CrNiMo	25	168.3	310	504	237	406	181	
	I030-1E4EF I031-1E4EF I034-1E4EF I035-1E4EF	Carbon steel 15 Mo 3 CrNi CrNiMo	50	168.3	354	608	237	406	181	
	I030-1E1EG I031-1E1EG I034-1E1EG I035-1E1EG	Carbon steel 15 Mo 3 CrNi CrNiMo	25	168.3	310	504	237	406		97
	I030-1E4EG I031-1E4EG I034-1E4EG I035-1E4EG	Carbon steel 15 Mo 3 CrNi CrNiMo	50	168.3	354	608	237	406		127
	I030-1E1EH I031-1E1EH I034-1E1EH I035-1E1EH	Carbon steel 15 Mo 3 CrNi CrNiMo	25	168.3	310	504	237	406		97
	I030-1E4EH I031-1E4EH I034-1E4EH I035-1E4EH	Carbon steel 15 Mo 3 CrNi CrNiMo	50	168.3	354	608	237	406		127

## INDUSTRIAL CHAMBERS

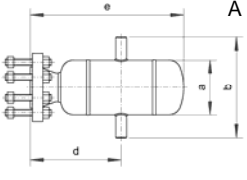
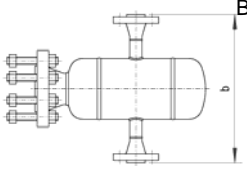
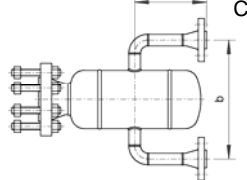
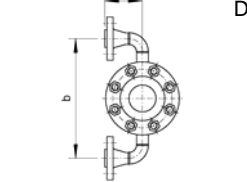
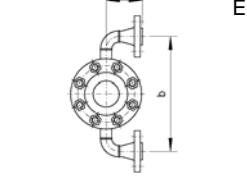
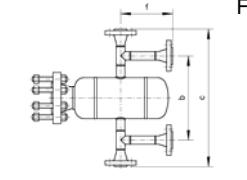
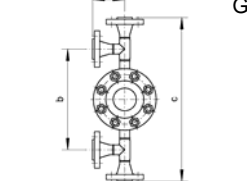
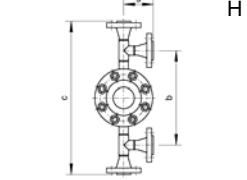
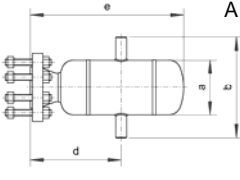
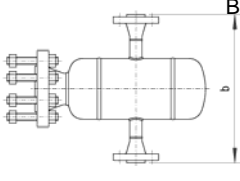
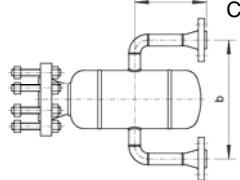
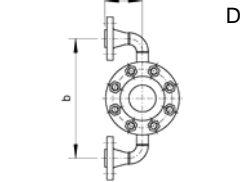
Table 11

Industrial chambers PN cl. 150, process connection DN acc. to ANSI / switch connection flange DN 3"

Figure	Type	Material	DN	Dimensions						
				a	b	c	d	e	f	g
	I110-1R1XA I114-1R1XA I115-1R1XA	Carbon steel CrNi CrNiMo	1"	141.3	320		243	420		
	I110-1R4XA I114-1R4XA I115-1R4XA	Carbon steel CrNi CrNiMo	2"	141.3	320		243	420		
	I110-1R1RB I114-1R1RB I115-1R1RB	Carbon steel CrNi CrNiMo	1"	141.3	307		243	420		
	I110-1R4RB I114-1R4RB I115-1R4RB	Carbon steel CrNi CrNiMo	2"	141.3	307		243	420		
	I110-1R1RC I114-1R1RC I115-1R1RC	Carbon steel CrNi CrNiMo	1"	141.3	272		243	420	194	
	I110-1R4RC I114-1R4RC I115-1R4RC	Carbon steel CrNi CrNiMo	2"	141.3	332		243	420	194	
	I110-1R1RD I114-1R1RD I115-1R1RD	Carbon steel CrNi CrNiMo	1"	141.3	272		243	420		95
	I110-1R4RD I114-1R4RD I115-1R4RD	Carbon steel CrNi CrNiMo	2"	141.3	332		243	420		141
	I110-1R1RE I114-1R1RE I115-1R1RE	Carbon steel CrNi CrNiMo	1"	141.3	272		243	420		95
	I110-1R4RE I114-1R4RE I115-1R4RE	Carbon steel CrNi CrNiMo	2"	141.3	332		243	420		141
	I110-1R1RF I114-1R1RF I115-1R1RF	Carbon steel CrNi CrNiMo	1"	141.3	272	462	243	420	194	
	I110-1R4RF I114-1R4RF I115-1R4RF	Carbon steel CrNi CrNiMo	2"	141.3	308	565	243	420	194	
	I110-1R1RG I114-1R1RG I115-1R1RG	Carbon steel CrNi CrNiMo	1"	141.3	272	462	243	420		95
	I110-1R4RG I114-1R4RG I115-1R4RG	Carbon steel CrNi CrNiMo	2"	141.3	308	565	243	420		129
	I110-1R1RH I114-1R1RH I115-1R1RH	Carbon steel CrNi CrNiMo	1"	141.3	272	462	243	420		95
	I110-1R4RH I114-1R4RH I115-1R4RH	Carbon steel CrNi CrNiMo	2"	141.3	308	565	243	420		129

Table 12

Industrial chambers PN cl. 300, process connection DN acc. to ANSI / switch connection flange DN 3"

Figure	Type	Material	DN	Dimensions						
				a	b	c	d	e	f	g
	I120-1R1XA I124-1R1XA I125-1R1XA	Carbon steel CrNi CrNiMo	1"	141.3	320		252	429		
	I120-1R4XA I124-1R4XA I125-1R4XA	Carbon steel CrNi CrNiMo	2"	141.3	320		252	429		
	I120-1R1RB I124-1R1RB I125-1R1RB	Carbon steel CrNi CrNiMo	1"	141.3	320		252	429		
	I120-1R4RB I124-1R4RB I125-1R4RB	Carbon steel CrNi CrNiMo	2"	141.3	320		252	429		
	I120-1R1RC I124-1R1RC I125-1R1RC	Carbon steel CrNi CrNiMo	1"	141.3	272		252	429	200	
	I120-1R4RC I124-1R4RC I125-1R4RC	Carbon steel CrNi CrNiMo	2"	141.3	332		252	429	200	
	I120-1R1RD I124-1R1RD I125-1R1RD	Carbon steel CrNi CrNiMo	1"	141.3	272		252	429		101
	I120-1R4RD I124-1R4RD I125-1R4RD	Carbon steel CrNi CrNiMo	2"	141.3	332		252	429		147
	I120-1R1RE I124-1R1RE I125-1R1RE	Carbon steel CrNi CrNiMo	1"	141.3	272		252	429		101
	I120-1R4RE I124-1R4RE I125-1R4RE	Carbon steel CrNi CrNiMo	2"	141.3	332		252	429		147
	I120-1R1RF I124-1R1RF I125-1R1RF	Carbon steel CrNi CrNiMo	1"	141.3	272	474	252	429	200	
	I120-1R4RF I124-1R4RF I125-1R4RF	Carbon steel CrNi CrNiMo	2"	141.3	308	578	252	429	200	
	I120-1R1RG I124-1R1RG I125-1R1RG	Carbon steel CrNi CrNiMo	1"	141.3	272	474	252	429		101
	I120-1R4RG I124-1R4RG I125-1R4RG	Carbon steel CrNi CrNiMo	2"	141.3	308	578	252	429		135
	I120-1R1RH I124-1R1RH I125-1R1RH	Carbon steel CrNi CrNiMo	1"	141.3	272	474	252	429		101
	I120-1R4RH I124-1R4RH I125-1R4RH	Carbon steel CrNi CrNiMo	2"	141.3	308	578	252	429		135

## INDUSTRIAL CHAMBERS

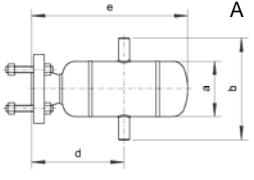
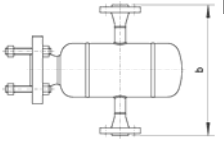
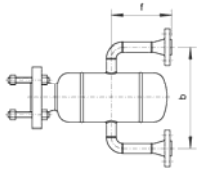
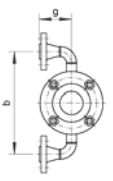
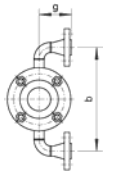
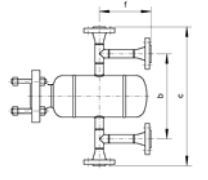
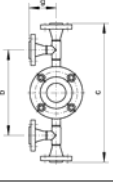
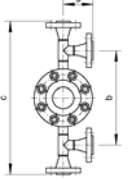
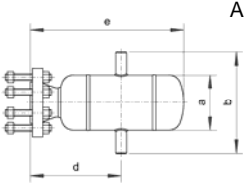
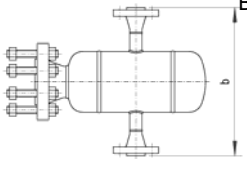
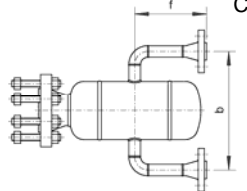
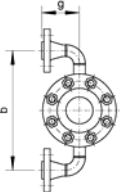
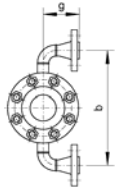
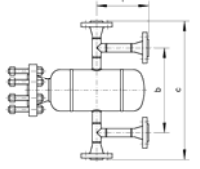
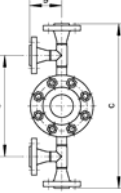
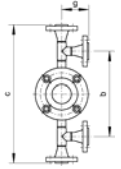
Table 13

Industrial chambers PN cl. 400/600, process connection DN acc. to ANSI / switch connection flange DN 3"

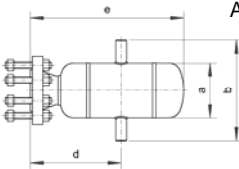
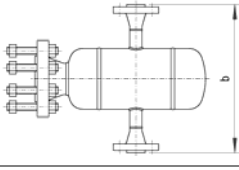
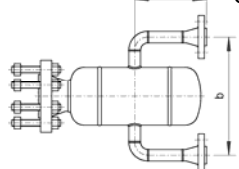
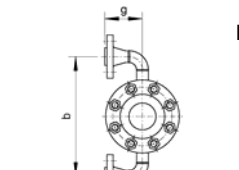
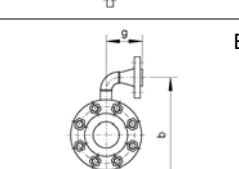
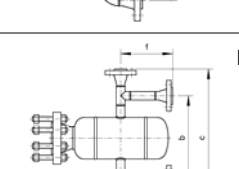
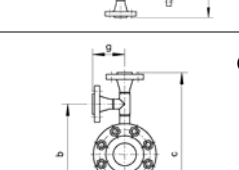
Figure	Type	Material	DN	Dimensions						
				a	b	c	d	e	f	g
	I140-1R1XA I144-1R1XA I145-1R1XA	Carbon steel CrNi CrNiMo	1"	168.3	320		276	466		
	I140-1R4XA I144-1R4XA I145-1R4XA	Carbon steel CrNi CrNiMo	2"	168.3	320		276	466		
	I140-1R1RB I144-1R1RB I145-1R1RB	Carbon steel CrNi CrNiMo	1"	168.3	350		276	466		
	I140-1R4RB I144-1R4RB I145-1R4RB	Carbon steel CrNi CrNiMo	2"	168.3	350		276	466		
	I140-1R1RC I144-1R1RC I145-1R1RC	Carbon steel CrNi CrNiMo	1"	168.3	302		276	466	200	
		I140-1R4RC I144-1R4RC I145-1R4RC	Carbon steel CrNi CrNiMo	2"	168.3	356		276	466	203
	I140-1R1RD I144-1R1RD I145-1R1RD	Carbon steel CrNi CrNiMo	1"	168.3	302		276	466		101
	I140-1R4RD I144-1R4RD I145-1R4RD	Carbon steel CrNi CrNiMo	2"	168.3	356		276	466		150
	I140-1R1RE I144-1R1RE I145-1R1RE	Carbon steel CrNi CrNiMo	1"	168.3	302		276	466		101
	I140-1R4RE I144-1R4RE I145-1R4RE	Carbon steel CrNi CrNiMo	2"	168.3	356		276	466		150
	I140-1R1RF I144-1R1RF I145-1R1RF	Carbon steel CrNi CrNiMo	1"	168.3	302	504	276	466	200	
	I140-1R4RF I144-1R4RF I145-1R4RF	Carbon steel CrNi CrNiMo	2"	168.3	332	608	276	466	203	
	I140-1R1RG I144-1R1RG I145-1R1RG	Carbon steel CrNi CrNiMo	1"	168.3	302	504	276	466		101
	I140-1R4RG I144-1R4RG I145-1R4RG	Carbon steel CrNi CrNiMo	2"	168.3	332	608	276	466		138
	I140-1R1RH I144-1R1RH I145-1R1RH	Carbon steel CrNi CrNiMo	1"	168.3	302	504	276	466		101
	I140-1R4RH I144-1R4RH I145-1R4RH	Carbon steel CrNi CrNiMo	2"	168.3	332	608	276	466		138

## Options for your specific application

The float chambers listed on page 4 to 14 are standard designs available on its shortest deliveries. Listed below are options which should be specified, if required, on your enquiry/order.

**Table 14**

Option	Standard chamber	Industrial chamber
Other flange facings on the process connection flanges	X	X
Other flange facings on the switch connection flanges		X
Special chamber dimensions	X	X
Special configurations (figures)	X	X
½" NPT drain and vent valves (fig. 1)	X	X
Extended bolts for mounting test actuators	X	
Float chambers up to PN 315 acc. to DIN and cl. 2500 acc. to ANSI		X
Float chambers acc. to NACE with max. hardness of 22 HRC	X	X
Double-walled chambers for thermal oil heating (fig.2)		X
Priming- and painting	X	X
Weld preparation for x-ray test	X	X
Dye penetrant testing	X	X
Ultra sonic and x-ray tests	X	X
Charpy-, hardness- und tensile tests	X	X

**fig. 1**  
Besta float chambers with drain and vent valves

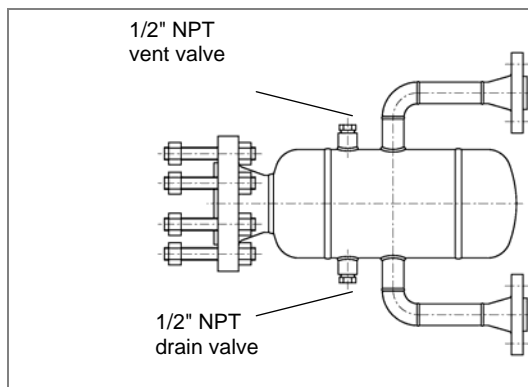

**fig. 2**  
Double-walled float chamber for thermal oil heating

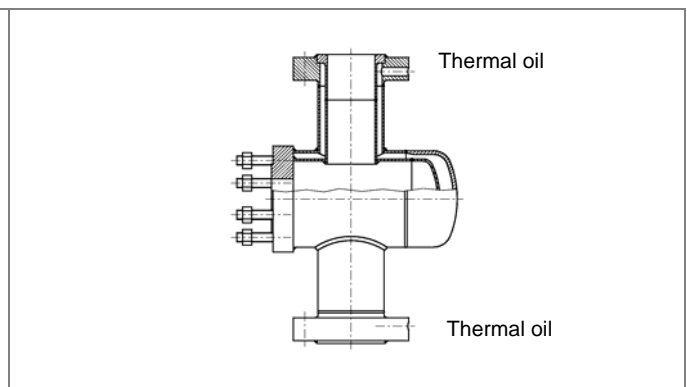

## Maximum operating pressures according to DIN 2401 and ANSI B16.5

Tables 15, 16 and 17 show the maximum operating pressures in relation to the process temperature.

**Table 15**  
Maximum operating pressures for standard chambers

PN	Material of float chamber	max. operating pressure in bar at temperature in °C					
		÷ 120	200	250	300	350	400
25	Carbon steel	25	22	20	17	16	13
	15 Mo 3			25	22	20	19
	CrNi / CrNiMo	25	22	20	17	16	13

**Table 16**  
Maximum operating pressures for industrial chambers acc. to DIN

PN	Material of float chamber	max. operating pressure in bar at temperature in °C					
		÷ 120	200	250	300	350	400
40	Carbon steel	40	35	32	28	24	21
	15 Mo 3			40	35	31	30
	CrNi / CrNiMo	40	35	32	28	24	21
63	Carbon steel	63	50	45	40	36	32
	15 Mo 3			63	56	50	47
	CrNi / CrNiMo	63	50	45	40	36	32

**Table 17**  
Maximum operating pressures for industrial chambers acc. to ANSI

PN cl.	Material of float chamber	max. operating pressure in bar at temperature in °C					
		100	200	250	300	350	400
150	Carbon steel CrNi / CrNiMo	17.7	14.0	12.1	10.2	8.4	6.5
		13.2	11.0	10.2	9.7	8.4	6.5
300	Carbon steel CrNi / CrNiMo	46.4	43.8	41.7	38.7	37.0	34.5
		34.5	28.7	26.7	25.2	24.0	23.2
400	Carbon steel CrNi / CrNiMo	61.8	58.4	55.6	51.6	49.3	46.0
		46.0	38.3	35.6	33.7	32.1	30.9
600	Carbon steel CrNi / CrNiMo	92.8	87.6	83.4	77.5	73.9	69.0
		69.0	57.4	53.4	50.5	48.1	46.3

## Our quality assurance program

Trimod Besta level switches in Besta float chambers are often employed for control and monitoring functions to provide security for both people and the environment. As manufacturers, we take this responsibility seriously. This quality control is for us not only a strong sales argument, but also an obligation.

1. Every Besta float chamber is cold hydraulic pressure tested. Test pressure 1.5x nominal pressure (depending on standard).
2. The industrial chambers are tested including mounted level switch. This guarantees tight sealing connections.
3. You will receive the original test certificate T-130 / T-121 on which the pressure test is recorded (fig. 3).
4. For every type of float chamber a drawing is provided with full component specifications (fig. 4) including heat nos, materials, dimensions and standards.
5. Additional tests are recorded on the test certification together with the original protocols.
6. For standard and industrial chambers the following material certificates are available
  - Test report acc. to EN 10204-2.2
  - Inspection certificates acc. to EN 10204-3.1

fig. 3  
Test certificate T-130 /T-121

Schwimmerkammer Float Chamber Chambre à flotteur	Abnahmeprüfzeugnis nach EN 10204-3.1 Inspection Certificate acc. to EN 10204-3.1 Certificat de réception selon EN 10204-3.1	T-121
<p>Unsere Auftragsnummer Our order number Votre no. de commande</p> <p>Typ Type</p> <p>Rückverfolgbarkeit: Bei Rückfragen ist die Angabe unserer Auftragsnummer zwingend. Traceability: With queries, the indication of our order number is mandatory. Traçabilité: En cas de demandes de précision, l'indication de votre no. de commande est contraignante.</p> <p>Kalt-Hydraulische Druckprüfung / Cold hydraulic pressure test / Essai de pression froid hydraulique</p> <p>Probitruck Test pressure</p> <p>Druckzeit / Exposure time</p> <p>Zusätzliche Prüfungen E-150 Additional examinations</p> <p>Examinations additionnelles</p> <p>Vorwerkzeug gemäß beiliegendem Zeugnis, Maximalität siehe Beiblatt. Primary material acc. to the attached certificate, Dimensional drawing see supplementary sheet. Matériau de base selon certificat de réception et joint, Épure voir supplément.</p> <p>Bemerkungen Notes Remarques</p> <p>Wir bestätigen hiermit, dass Qualität und Menge der gelieferten Ware von der Qualitätsicherung geprüft ist und die Vorschriften genaue Befolgung sowie die allgemein gültigen Normen eingehalten sind. We confirm that the quality and quantity of the above mentioned goods have been checked by our Quality Assurance Department and that the goods comply with the specifications according to the purchase order and the relevant standards. Nous confirmons que la qualité et quantité de la marchandise fournie ont été examinées, et les instructions selon la commande et les normes générales en ont été respectées.</p> <p>Beilagen Enclosure</p> <p>Zeugnisse Certificates</p> <p>Beiblatt Supplementary sheet</p> <p>Nr. No.</p> <p>Ort, Datum Place, date</p> <p>Unterschrift Signature</p>		
<p>Besta AG, Schwanensee 88, CH-8910 Olten, Switzerland Phone +41 85 885 15 15, Fax +41 85 885 15 80 Email info@besta.ch, help@besta.ch</p> <p><b>BESTA</b></p>		

fig. 4  
Float chamber drawing with  
component specification



EXPERTS RELY ON BESTA

## Certified quality

The following approvals and certification in addition to periodic audits by BVQI are the core of our quality assurance philosophy which guarantees the highest possible standards for fabrication and test procedures.

### EC-Declaration of Conformity

PED 97 / 23 / EC

### EC-Design Examination Certificate

CE-PED-BI-BES 001-02-CHE

### Procedure qualification record

acc. to

- SVTI 505
- AD HP 2/1
- ASME Code Sec. IX

### Approved welders

acc. to

- SVTI 504
- AD HP 3
- ASME Code Sec. IX

### Material transfer stamping

acc. to

- SVTI 201/507

### Spezifikation sheet

### Data sheet LTKD03E

Trimod <sup>B</sup> Besta		Manufacturing Specs	
		Data Sheet LTKD03E	
<b>1. Pressure vessel calculation</b>			
The calculations are based on the AD-rules (German Association for Pressure Vessels), or are designed in conformity to ASME VIII.			
<b>2. Welding Procedure</b>			
LEVEL I		LEVEL II	
Industrial welding procedure to ASME IX / SVDR, see back page		Industrial welding procedure to ASME IX / SVDR, see back page	
Full penetration welding suitable for NDE		Full penetration welding not suitable for NDE	
Weld joint preparation for NDE testing		Part penetration welding not suitable for NDE requirements	
<b>2a. Weld procedure</b> GTAW/GMAW-SMAW/TIG/MAG-MIG			
<b>2b. Assessment</b> EN ISO 5817 Level B			
<b>3. Heat treatment</b>			
Pre- and post weld heat treatment for high temperature steel only, e.g. 13 CrMo 4.4 (1.7335), A 335 Gr. P12, A 234 Gr. WP11, A 182 Gr. F12 other materials upon request.			
Stress-free annealing:	Annealing temperature: 650 - 720°C	Cooling:	with cover gas
	Time: approx. 2 h	Report:	T-t diagram
<b>4. Material tests</b>			
Non destructive examination of chambers manufactured according to LEVEL I, see back page			
Radiographic film material remains the property of Besta AG and is filed for 10 years.			
<b>5. Hydrostatic test</b>			
100% cold hydraulic pressure test		Test pressure: DNI-chambers: PO, acc. AD 2000	
Report: Test certificate T-130		ANSI-chambers: 1.5 x PO, acc. ASME	
		PO = max. allowable working pressure	
<b>6. Surface protection / Coating</b>			
Standard:	Carbon steel (St): Enslut Activprimer / basalt grey –RAL 7012		
	Stainless steel (St): pickled		
Option A:	Carbon steel: up to max. operating temperature 100°C		
T-187	Surface preparation: sand- or corundum blasting		
	Primer: ETOZINC zinc powder primer	Epoxy-Polyamide resin	1 x 50 micro
	Undercoat: ETOKAT filler	Epoxy-Polyamide resin	2 x 50 micro
	Finish: NUVOVERN ACR gloss GL	Polyurethane two-component enamel based resin	1 x 50 micro
	Colour: RAL 5010, blue		
Option B:	Carbon steel: up to max. operating temperature 400°C		
T-188	Surface preparation: corundum blasting		
	Primer: SILKNOX HT zinc dust primer	Silicone basis	1 x 30 micro
	Finish: IMERT silicone enamel SDGL	Silicone basis	2 x 20 micro
	Colour: aluminum semi-gloss		
Option C:	Stainless steel: up to max. operating temperature 150°C		
T-189	Surface preparation: corundum blasting		
	Primer: ETOKAT Aktiv-Primer	Epoxy resin basis	1 x 30 micro
	Finish: NUVOVERN ARC-Emallack GL	Polyurethane basis	1 x 30 micro
	Colour: RAL 5010, blue		
<b>7. Studs and nuts</b>			
Carbon steel	DN (-10° to +400°C)	Studs A 190-B7	Nuts A 194-2H
	ANSI (-20° to +400°C)	Studs A 190-B7	Nuts A 194-2H
Low temperature material	DN (<-10°C), ANSI (<-29°C)	Studs A 320-L7	Nuts A 194-4
<b>8. Gaskets</b>			
Switch connection flange:	Material: AFM 34	for sealing:	raised face
	stainless steel	for sealing:	ring joint
<b>9. Certificates</b>			
Option:	Material certificates to EN 10204 (DIN 50049) 2.2 / 3.1 / 3.2		Marking: die-stamped
	The requested material certificate must be specified with the order.		
PED:	Chamber manufactured acc. to directive PED incl. letter of conformity.		

**Float chamber specification sheet**

We gladly determine the ideal float chamber for your application if you send us a filled in copy of this form. The more detailed your information, the more accurate we can determine the float chamber. Please tick the appropriate box (X).

Customer Name	_____	Date	_____
Address	_____	Telephone	_____
	_____	Email	_____
Standard	<input type="checkbox"/> DIN	<input type="checkbox"/> ANSI	<input type="checkbox"/> Besta
Figure	<input type="checkbox"/> A	<input type="checkbox"/> B	<input type="checkbox"/> C
	<input type="checkbox"/> D	<input type="checkbox"/> E	<input type="checkbox"/> F
	<input type="checkbox"/> G	<input type="checkbox"/> H	
Application data	Operating pressure _____ bar	Operating temperature _____ °C	
	Design pressure _____ bar	Design temperature _____ °C	
Connection	Switch connection flange/flange facing	_____	
	Process connection flange /flange facing	_____	
	Distance between process connection flanges (dimension b)	_____	
	Drain/vent	<input type="checkbox"/> Flange	<input type="checkbox"/> Socket
		<input type="checkbox"/> No	
	Painting	<input type="checkbox"/> Yes	<input type="checkbox"/> No
Material	<input type="checkbox"/> Carbon steel	<input type="checkbox"/> CrNi-steel	
	<input type="checkbox"/> Low temperature carbon steel	<input type="checkbox"/> CrNiMo-steel	
	<input type="checkbox"/> Heat resistant carbon steel	<input type="checkbox"/>	
Inspection, test, treatment	<input type="checkbox"/> Radiographic test	<input type="checkbox"/> Magnetic particle test	
	<input type="checkbox"/> Dye penetrant test	<input type="checkbox"/> Heat treatment	
	<input type="checkbox"/> Ultrasonic test	<input type="checkbox"/>	
Test certificate	<input checked="" type="checkbox"/> T-130 Test certificate according to EN 10204-2.2 included		
	<input type="checkbox"/> T-121 Inspection certificate according to EN 10204-3.1		



Besta Ltd.  
Ackerstrasse 45  
CH-8610 Uster  
Switzerland  
Phone +41 43 399 15 15  
Fax +41 43 399 15 00  
info@besta.ch  
www.besta.ch

### **Homepage**

Find your local sales und service partner under  
[www.besta.ch](http://www.besta.ch)

### **Quality Management**

The Besta Ltd. quality management system  
according to ISO 9001 has been established in 1991.

### **Registered Trade Marks**

Trimod and Besta are registered trade marks of  
Besta Ltd., Switzerland.